

Kunde / Customer:

Projekt / Project: _____

Zangen typ / type of gun:

X-Bauform

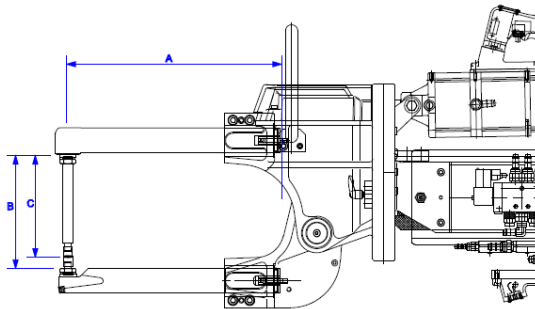

C-Bauform

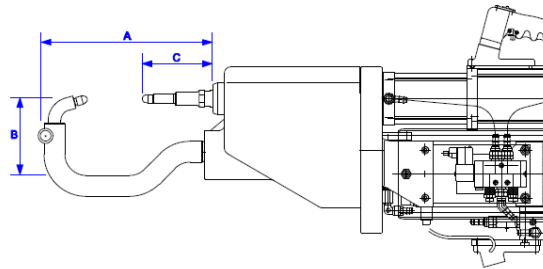

Ausladung A in mm:
(Throat) _____

Armabstand B in mm:
(Arm distance) _____

Schaftlänge C in mm:
(Shaft length) _____

Vorhub in mm:
(Retract) _____

Arbeitshub in mm:
(Working stroke) _____

Netzdruck in bar:
(Air pressure in bar) _____

Material

Blech 1 / sheet 1: _____

Blech 2 / sheet 2: _____

Blech 3 / sheet 3: _____

verzinkt/ galvanized

Ja / Yes

Nein/ No

Materialstärke in mm/
Thickness of material in mm

Blech 1 / sheet 1: _____

Blech 2 / sheet 2: _____

Blech 3 / sheet 3: _____

Punkte pro Minute:
(Spots per minute) _____

Länge Kabel-/Schlauchpaket in m:
(Lenght of cable/hose package) _____

Bemerkungen / Information (notes):

Beispiel / example:

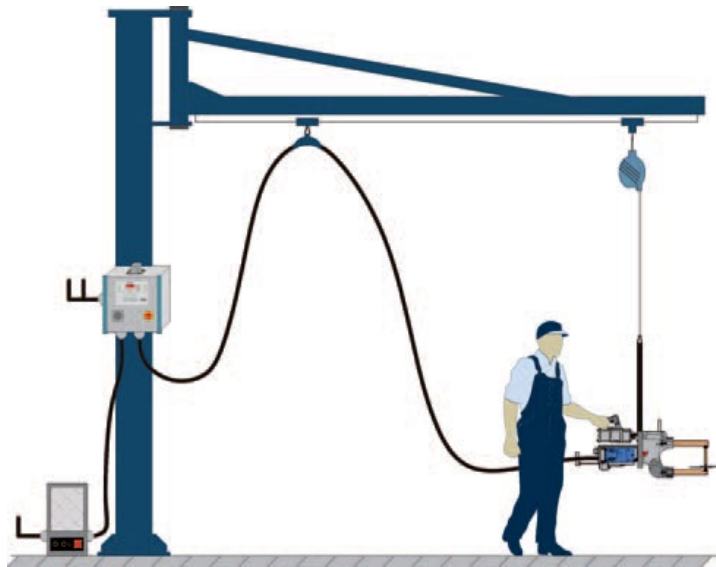

Zubehör / Accessories:

<u>Pos.</u>	<u>Artikel / article</u>	<u>Notwendig / Required</u>
1	Federzüge / Balancer:	
2	Steuerung / Control:	
3	Kühlwasser-Rückkühler: (Cooling water heat exchanger)	
4	Abhängematerial: (Mounting material)	
5	Schnell-Wechsel-System: (quick-change-system)	

Bitte per E-Mail an (please forward via mail to)

Carsten.Demmer@nimak.de